

25.75 DIA.
(24" ID)

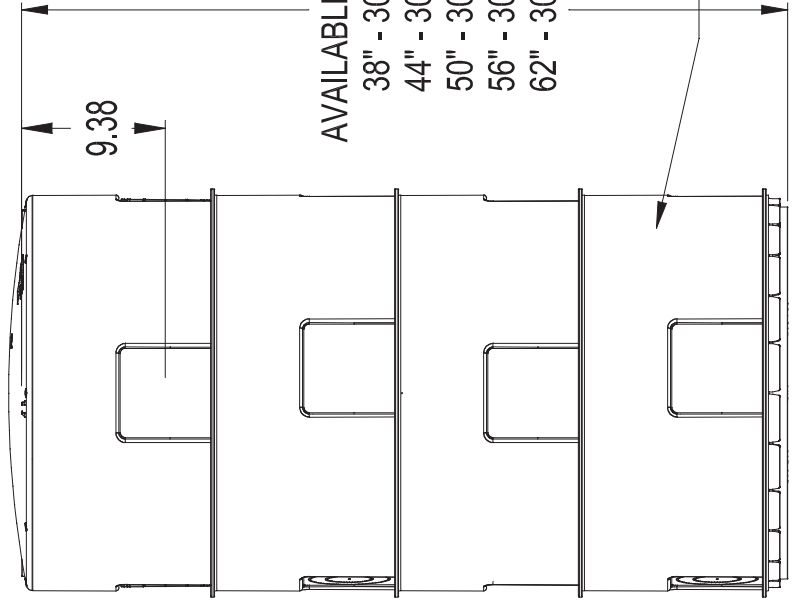

AVAILABLE SIZES:

- 38" - 3008CUS-38
- 44" - 3008-CUS44
- 50" - 3008-CUS50
- 56" - 3008-CUS56
- 62" - 3008-CUS62

EACH 12" SECTION =
25 GALLONS CAPACITY

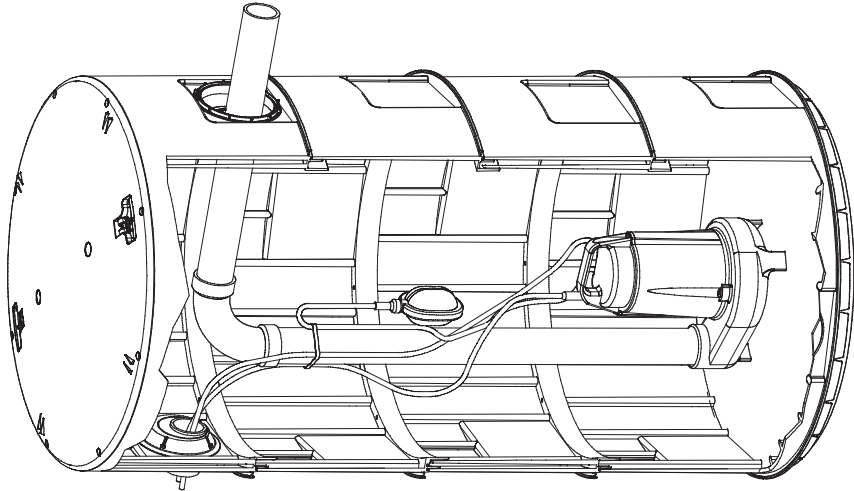

PUMP/SUMP BASIN

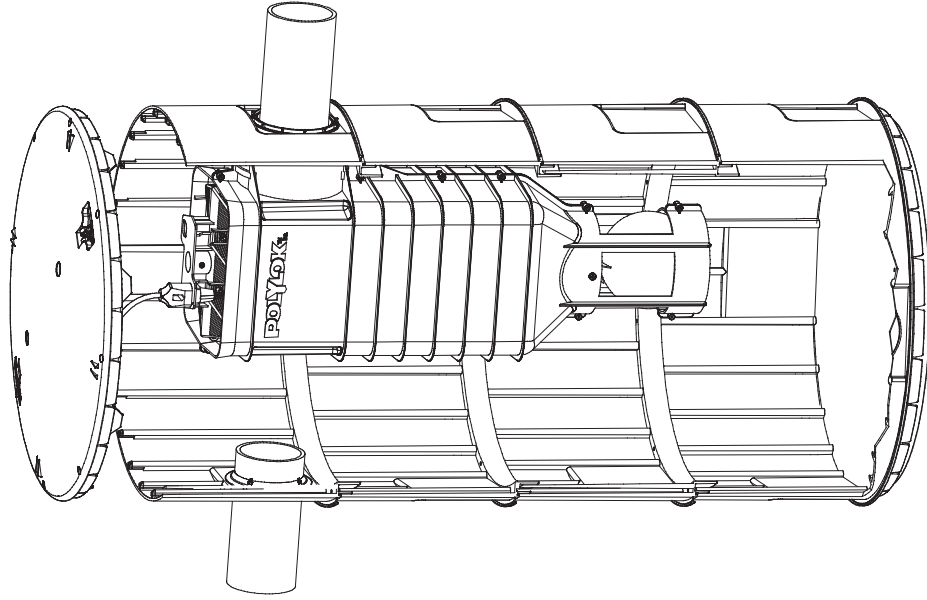

FILTER BASIN

POLYLOK 24" BASINS
PART NO. 3008-CUS

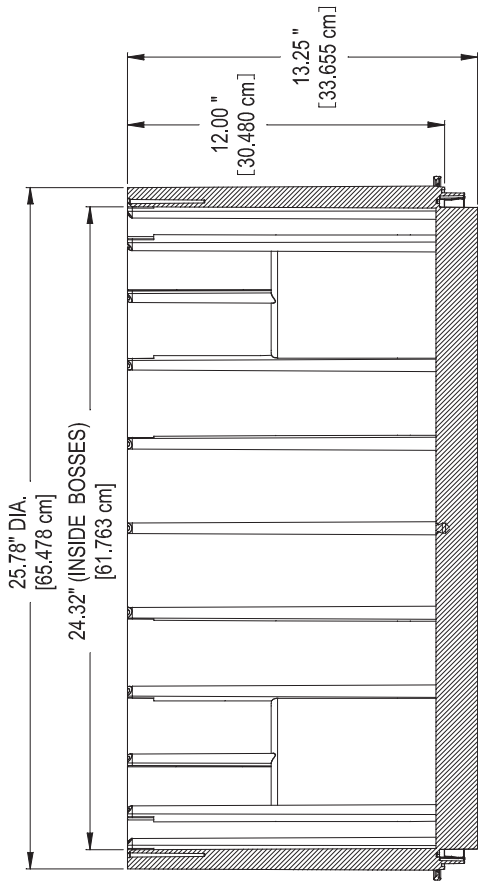

SECTION A-A

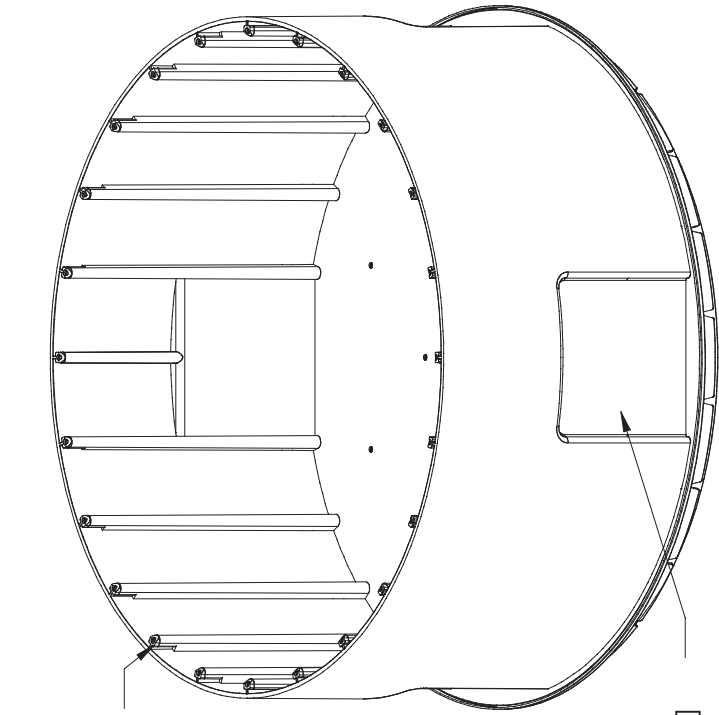

TOP DETAIL FITS POLYLOK
 PART NO. - 3008
 3008-RC
 3008-R12
 3008-G24
 3008-HD
 3008-RP

4 - 6" x 6" [15.24 cm X 15.24 cm]
 PANELS TO ALLOW
 FOR EASY WALL PENETRATION
 USING WATER TIGHT GROMMETS

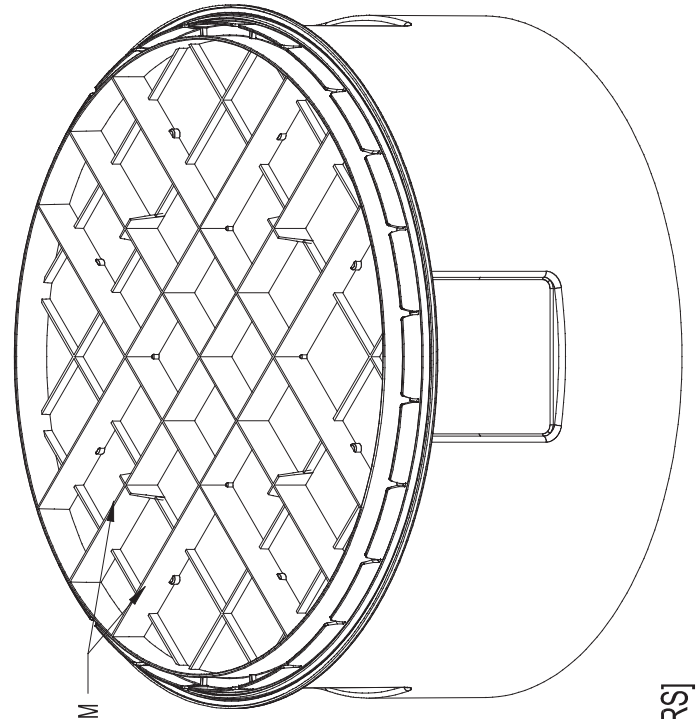

RIBBED BOTTOM

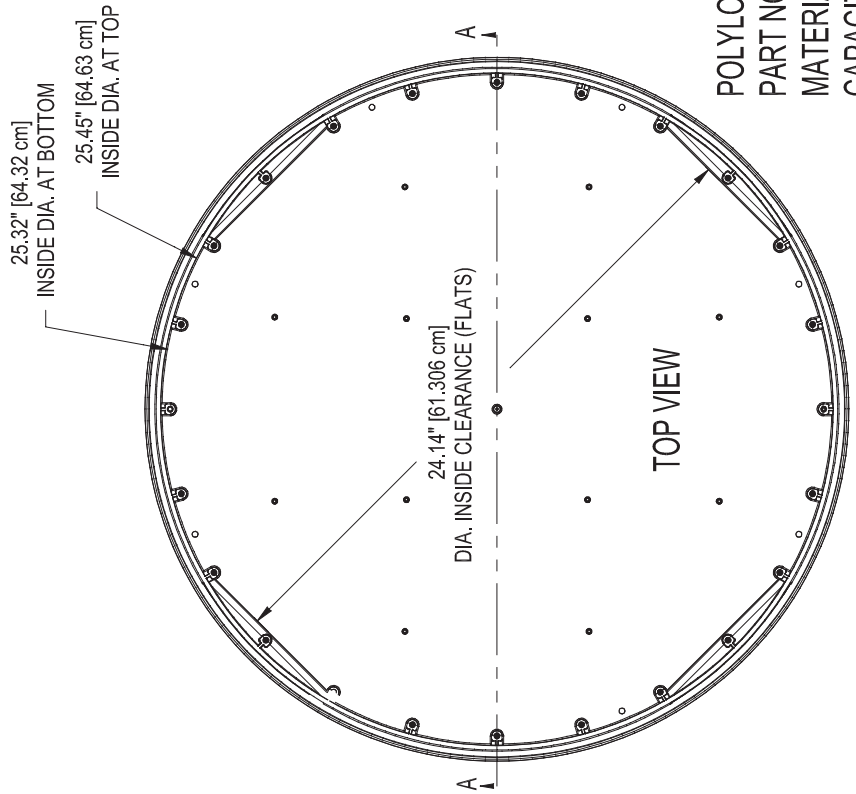

TOP VIEW

POLYLOK 12 X 24 BASIN
 PART NO. 3008-R12B
 MATERIAL - HDPE
 CAPACITY - 12" TALL BASIN - 25 GALLONS [94.5 LITERS]

Basin Application Guide

To insure Polylok basins are installed correctly the tank outlet height to grade has to be known. The typical inlet/outlet openings in a filter basin are four inches and pipe gaskets will require a five-inch hole to be drilled on both the inlet side and outlet side with a two-inch drop. The filter should clear the bottom of a filter basin by twelve inches. Different filter lengths may require adding additional risers. You need to know if the inlet/outlet pipes are schedule 40 or SDR 35 so the correct grommets ship with the basin. All inlet/outlet holes are drilled in the field. In a pump basin application the inlet/outlet pipe sizes must be known, the typical size is four inches on the inlet and two inches on the outlet. The 24x 38 inch basin is pre-assembled and shipped as a package, additional risers, 24 inch HD gaskets or grommets are shipped for field installation. All assembled risers to complete a basin must include **All HD gaskets** and **All screws**. Screws are stainless steel #10 x1.5 inches and tightened with an alternate tightening pattern. When a power tool is used to tighten screws make sure the power setting is either summer or winter, don't over-tighten screws or you could strip the screw hole out. In case of a hole that strips you can reset the riser or cover to the next group of holes and retighten the screws.

See diagram below for typical setup:

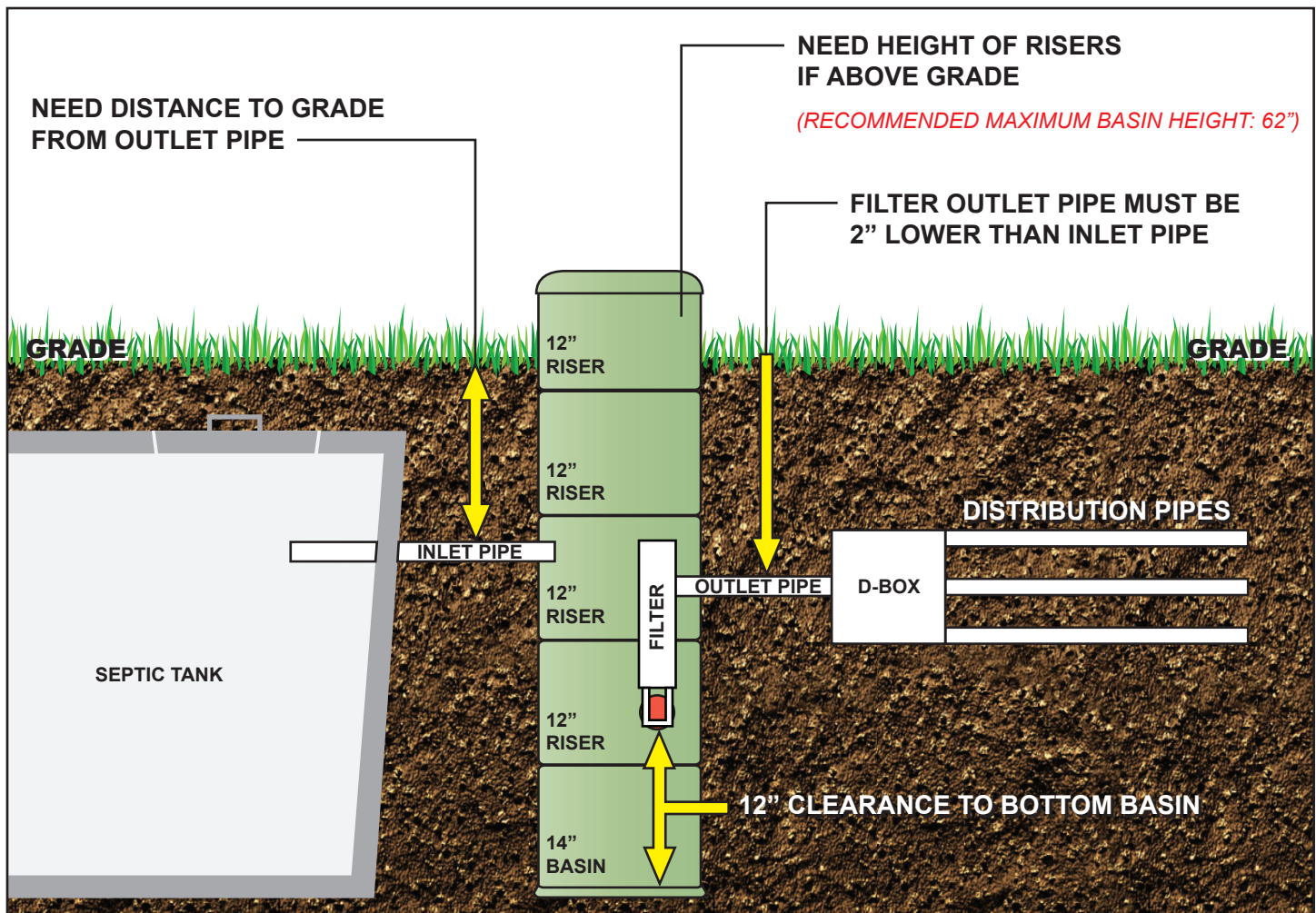

Polylok Basin Installation Instructions:

1. Inspect all materials supplied by Polylok/Zabel to assure there are no damages due to shipping or shortages prior to installation.

2. Excavate a hole for the basin large enough to accommodate the basin, underground piping, backfill material and adequate working space.

3. Prepare the bottom of the excavated hole with 6 inches of backfill material or concrete pad. Check hole base to make sure it's level and smooth.

4. Install the basin on a gravel base or concrete pad, anchor if necessary.

NOTE: In areas of high ground water an anchor may be required to stabilize the basin and prevent movement.

5. Concrete may be poured around the basin bottom if ballast is required to accommodate a buoyancy condition.
(SEE NOTE ABOVE)

6. Backfill with pea gravel 4 to 6 inches around the entire periphery of basin. Compact backfill material in 12 inch lifts, stopping to install piping as required.

Recommended Backfill Material:

Gravel or stone to be free flowing naturally rounded aggregate with a particle size of not less than 3/8 inch or larger than 3/4 inch in diameter.

CAUTION:

If burial depth is greater than the basin height, consult with factory representative to assure structural integrity is not compromised.

NOTE: Reinforcement may be necessary.

In freezing conditions backfill material must be dry and free of ice. Do not use backfill material such as site materials.

Warranty will be voided if the above procedures are not followed with other than approved backfill materials.

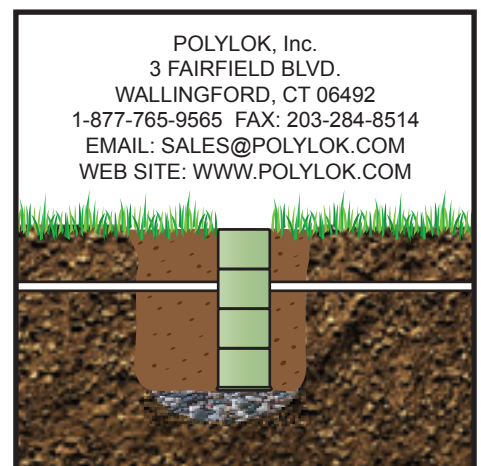
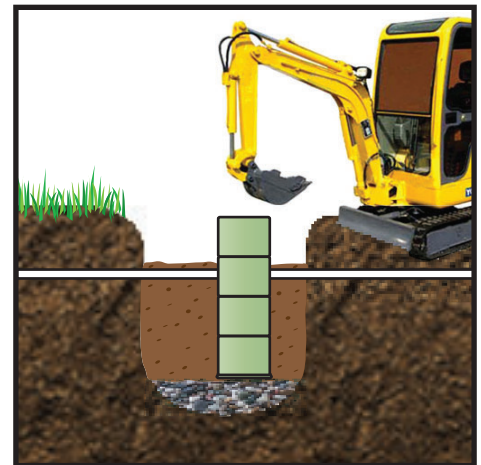
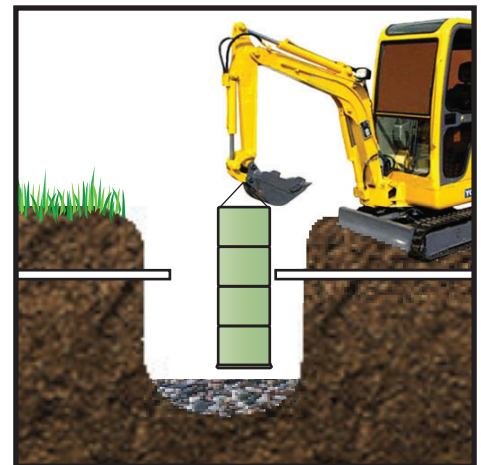
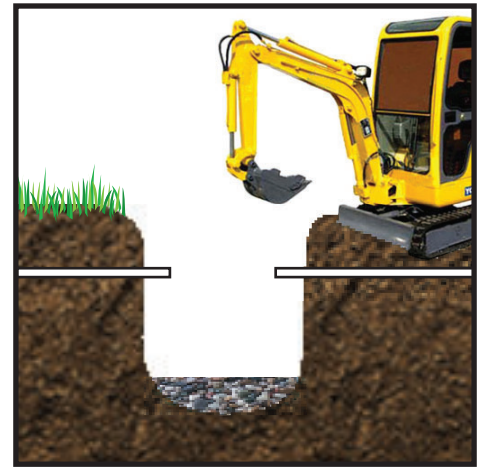

POLYLOK, Inc.
 3 FAIRFIELD BLVD.
 WALLINGFORD, CT 06492
 1-877-765-9565 FAX: 203-284-8514
 EMAIL: SALES@POLYLOK.COM
 WEB SITE: WWW.POLYLOK.COM